



BTBM-01

Bass/Treble/Bright Stack & Two Input Mixer

The BTBM-01 is divided into two separate sections:

- * Dual concentric Bass/Treble stack with Bright function.
- * Two Input Mixer stage which allows electronic mixing of two individual signals, such as those from a piezo preamp and magnetic pickups circuit.

- **BASS & TREBLE Stack**

- **TREBLE (+12dB @ 3 kHz, -12dB @ 1kHz)**

The upper knob is the Treble control with boost and cut. The central 'flat' position is indented. The cut settings work on lower frequencies compared to boost to give a deeper sound when the top is rolled off.

- **BRIGHT (+8dB @ 7kHz)**

Pull the Treble knob for the Bright setting.

- **BASS (+15dB @ 50Hz)**

The lower outer knob is the boost only Bass control. The frequency band of boost gets progressively lower as the boost is increased. An indent midway is included to aid the setting of this control.

- **TWO INPUT MIXER STAGE**

Consists of a low noise unity gain mixer stage with a low impedance output.

- **POWER**

This unit can powered from 9 - 18 Volts DC.

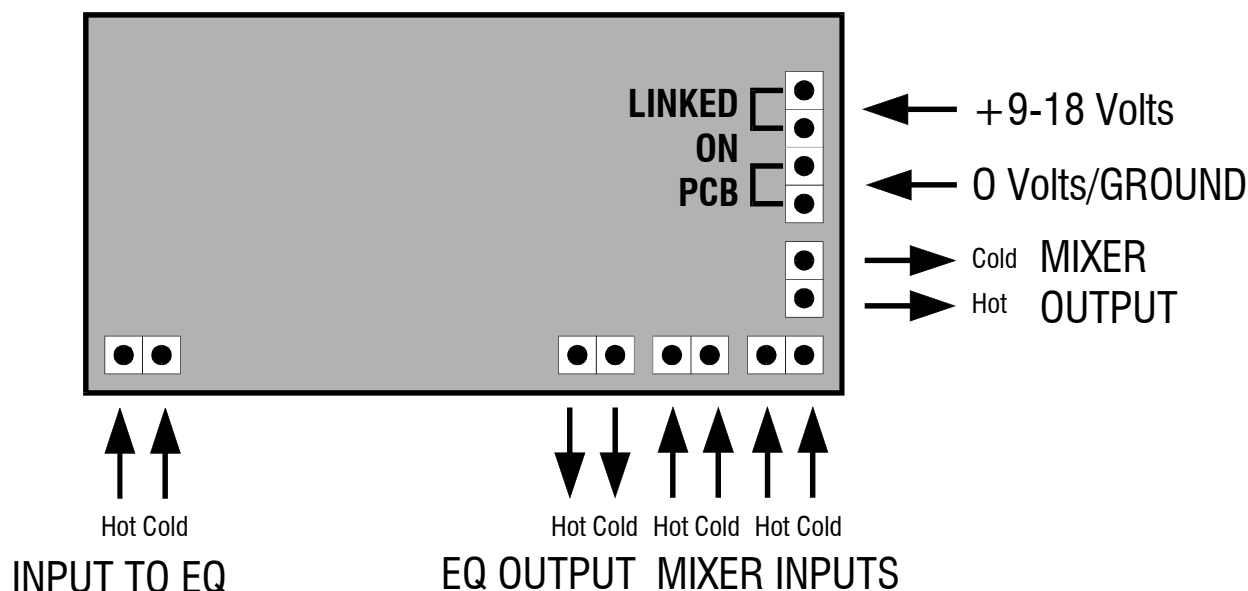

NOTE: All 'Cold' pins are linked to each other, and the '0 Volts/GROUND' pins. Therefore if a connection is made from the 'EQ OUTPUT' to a 'MIXER INPUT', for example, connect just the 'Hot' pins. It is not necessary to connect the 'Cold' pins in this instance.